

Dubbele contactdoos

Bestelnr. 98119



- schroefklemmen
- CEE- en SCHUKO® contactdoos in één behuizing
- beveiliging SCHUKO®: 1 installatieautomaat 16 A, 1 p, K

Technische informatie

CEE 32 A, 5 p, 400 V	1
SCHUKO®	1
Beschermingsgraad	IP 44
Aanrakingsveiligheid	false
Behuizing materiaal	Kunststof
Gewicht	1292 g
Hoogte	225 mm
Breedte	118 mm

Tekeningen

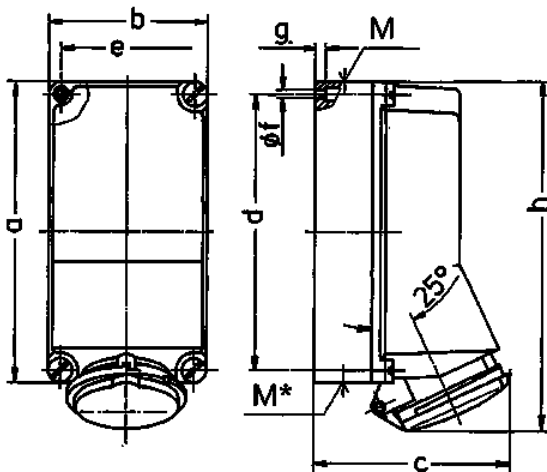

Tekening 1 MB 285		16	32	63
Maten in mm	Amp.			
a		225	225	264
b		118	118	163
c		141	146	194
d		208	208	240
e		101	101	140
f		6,3	6,3	8,1
g		8	8	8
h		254	264	300
M		1x25 en 1x32	1x25 en 1x32	40
M*		2x25	2x25	40