

## Wandcontactdoos

Bestelnr. 3147



- schroefklemmen
- binnenliggende bevestiging
- kabelinvoer 1 x boven en 1 x onder (blind)
- behuizing 180° draaibaar

## Technische informatie

Ampère	32 A
Polen	4 p
Voltage	na scheidingstransformator
Uurstand	12 h
Aansluittechniek	schroefklemmen
Contacten	standaard
Beschermingsgraad	IP 44
Gewicht	370 g
Certificeringen	EAC, CQC

## Tekeningen

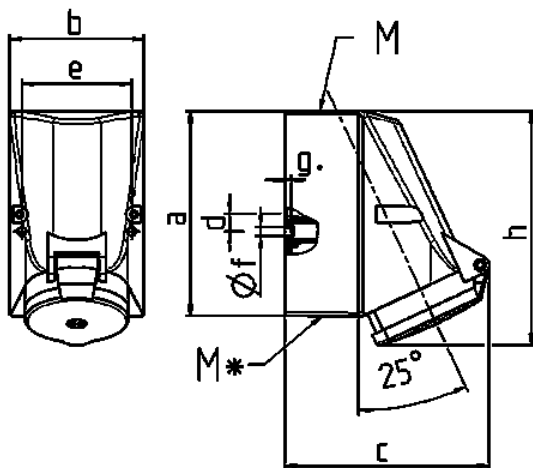

Tekening	Amp.	16		32		
		4	5	3	4	5
<b>1 MB 43</b>	<b>Polen</b>					
<b>Maten in mm</b>	<b>a</b>	128	128	128	128	128
	<b>b</b>	84	84	84	84	84
	<b>c</b>	122	124	136	136	138
	<b>d</b>	11	11	11	11	11
	<b>e</b>	68	68	68	68	68
	<b>f</b>	5,3	5,3	5,3	5,3	5,3
	<b>g.</b>	4	4	4	4	4
	<b>h</b>	144	145	158	158	160
	<b>M</b>	25	25	32	32	32
	<b>M*</b>	2x25 (blind) breekpoort		2x25 (blind) breekpoort		
<b>Kabel Ø tot mm</b>		18	18	18/25	18/25	18/25
<b>Kabelaansluiting</b>		1,5	1,5	2,5	2,5	2,5
<b>van/tot mm²</b>		—4	—4	—10	—10	—10