

## Wandcontactdoos

Bestelnr. 2152



- schroefklemmen
- binnenliggende bevestiging
- kabelinvoer 1 x boven en 1 x onder (blind)

## Technische informatie

Ampère	16 A
Polen	3 p
Voltage	50-250 V
Uurstand	3 h
Aansluittechniek	schroefklemmen
Contacten	standaard
Beschermingsgraad	IP 44
Gewicht	180 g
Certificeringen	EAC

## Tekeningen

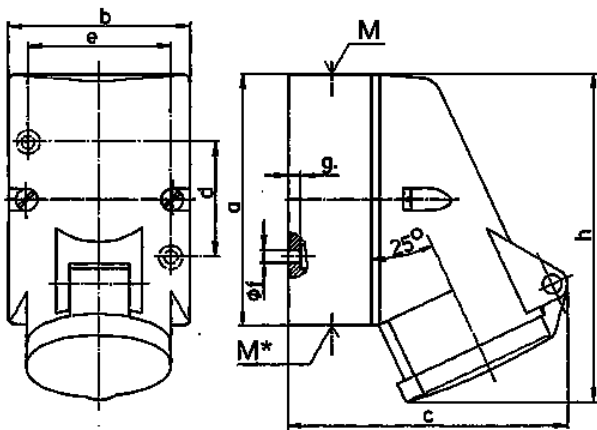

Tekening	Amp.	16
<b>1 MB 369</b>	<b>Polen</b>	<b>3</b>
<b>Maten in mm</b>	<b>a</b>	87
	<b>b</b>	64
	<b>c</b>	99
	<b>d</b>	40
	<b>e</b>	50
	<b>f</b>	4,5
	<b>g.</b>	4
	<b>h</b>	115
	<b>M</b>	20
	<b>M*</b>	20 (blind) breekpoort
<b>Kabel Ø tot mm</b>		15
<b>Kabelaansluiting</b>		1,5
<b>van/tot mm²</b>		—4