

Twinbox met TwinCONTACT

Bestelnr. 1647



- schroefloos met insteekklemmen
- CEE- en contactdoos SCHUKO® in één behuizing

Technische informatie

CEE 16 A, 4 p, 230 V	1
SCHUKO®	1
Beschermingsgraad	IP 44
Aanrakingsveiligheid	false
Behuizing materiaal	Kunststof
Gewicht	360 g
Certificeringen	EAC

Tekeningen

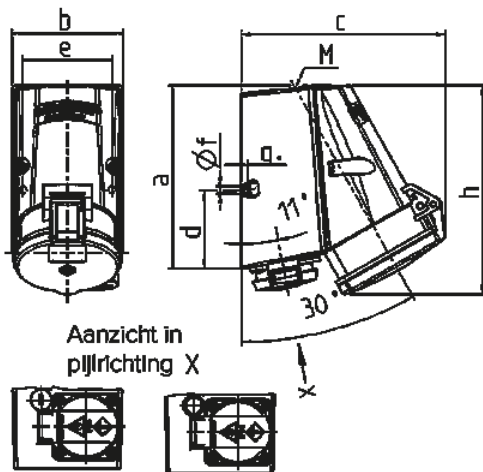

Tekening	Amp.	16		32
		4	5	5
1 MB 354	Polen			
Maten in mm	a	141	141	141
	b	84	84	85
	c	136	140	158
	d	61	61	61
	e	68	68	68
	f	5,5	5,5	5,5
	g.	5	5	5
	h	142	145	161
	M	25	25	25
Kabel Ø tot mm		18	18	18
Kabelaansluiting		1,5	1,5	2,5
van/tot mm²		—4	—4	—10